



Count on it.



Form No. 3378-765 Rev A

ΚΗΠΟΓΕΩΡΓΙΚΗ

ΦΥΤΑ - ΜΗΧΑΝΗΜΑΤΑ - ΕΡΓΑΛΕΙΑ

18ο χλμ. Εθνικής Οδού ΑΘΗΝΩΝ-ΚΟΡΙΝΘΟΥ

Τηλέφωνο: 2105573739

E-mail: info@kipogeorgiki.gr

Operator's Manual

20in Turf Seeder

Model No. 23510—Serial No. 312000001 and Up

Model No. 33510—Serial No. 312000001 and Up



G016883



▲ WARNING

**CALIFORNIA
Proposition 65 Warning**

This product contains a chemical or chemicals known to the State of California to cause cancer, birth defects, or reproductive harm.

The engine exhaust from this product contains chemicals known to the State of California to cause cancer, birth defects, or other reproductive harm.

Because in some areas there are local, state, or federal regulations requiring that a spark arrester be used on the engine of this machine, a spark arrester is available as an option. If you require a spark arrester, contact your Authorized Toro Service Dealer.

Genuine Toro spark arresters are approved by the USDA Forestry Service.

Important: It is a violation of California Public Resource Code Section 4442 to use or operate the engine on any forest-covered, brush-covered, or grass-covered land without a spark arrester muffler maintained in working order, or the engine constricted, equipped, and maintained for the prevention of fire. Other states or federal areas may have similar laws.

The enclosed *Engine Owner's Manual* is supplied for information regarding the US Environmental Protection Agency (EPA) and the California Emission Control Regulation of emission systems, maintenance, and warranty. Replacements may be ordered through the engine manufacturer.

Introduction

This machine seeds, dethatches, and power rakes turf both for revitalizing existing turf and for spreading seed. It is intended for small to medium sized lawn applications in residential and commercial properties.

Read this information carefully to learn how to operate and maintain your product properly and to avoid injury and product damage. You are responsible for operating the product properly and safely.

You may contact Toro directly at www.Toro.com for product and accessory information, help finding a dealer, or to register your product.

Whenever you need service, genuine Toro parts, or additional information, contact an Authorized Service Dealer or Toro

Customer Service and have the model and serial numbers of your product ready. Figure 1 illustrates the location of the model and serial numbers on the product. Write the numbers in the space provided.

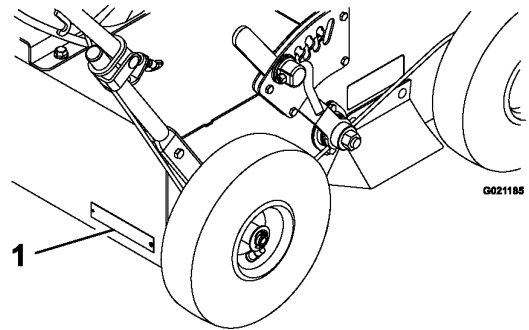

Figure 1

1. Location of the model and serial numbers

Model No. _____
Serial No. _____

This manual identifies potential hazards and has safety messages identified by the safety alert symbol (Figure 2), which signals a hazard that may cause serious injury or death if you do not follow the recommended precautions.



Figure 2

1. Safety alert symbol

This manual uses 2 words to highlight information.

Important calls attention to special mechanical information and **Note** emphasizes general information worthy of special attention.

Contents

Introduction	2
Safety	4
Safe Operating Practices.....	4
Safety and Instructional Decals	5
Setup	8
Unfolding the Handle	8
Checking the Engine Oil Level	8
Product Overview	8
Controls	9
Specifications	10
Torque Requirements.....	10
Attachments/Accessories.....	10
Operation	11
Checking the Engine Oil Level	11
Adding Fuel.....	11
Starting and Stopping the Engine.....	12
Operating the Self-propel Drive.....	13
Operating the Blade-control Bail	13
Operating the Machine.....	13
Adjusting the Cutting-blade Depth	14
Adjusting the Seeding-rate Gauge	14
Checking the Seed Gate.....	15
Operating Tips.....	15
Transporting the Machine.....	15
Maintenance	16
Recommended Maintenance Schedule(s)	16
Premaintenance Procedures	16
Disengaging the Hydrostatic Drive.....	16
Disconnecting the Spark-plug Wire	17
Lubrication	17
Lubricating the Slicer-shaft Bearings	17
Engine Maintenance	18
Servicing the Air Cleaner	18
Servicing the Engine Oil.....	18
Servicing the Spark Plug.....	19
Checking the Spark Arrester (if equipped)	19
Fuel System Maintenance	20
Emptying the Fuel Tank	20
Drive System Maintenance	21
Checking the Tire Pressure	21
Adjusting the Self-propel Drive	21
Changing the Hydraulic-transmission Fluid	21
Belt Maintenance	22
Checking the Condition of the Belts	22
Adjusting the Self-propel Drive-belt Tension	22
Maintaining the Cutting Blades	23
Checking and Replacing the Blades	23
Seed Gate Maintenance.....	25
Adjusting the Seed-gate Closed Position	25
Cleaning	25
Cleaning the Engine Area	25
Cleaning under the Machine.....	25
Cleaning under the Belt Cover	26
Cleaning the Seed Gate.....	26
Storage	27
Removing the Machine from Storage.....	27

Safety

Improperly using or maintaining the machine can result in injury. To reduce the potential for injury, comply with these safety instructions and always pay attention to the safety alert symbol, which means *Caution, Warning, or Danger*—personal safety instruction. Failure to comply with the instruction may result in personal injury or death.

Safe Operating Practices

Training

- Read the *Operator's Manual* and other training material. If the operator(s) or mechanic(s) cannot read or understand the information, it is the owner's responsibility to explain this material to them.
- Become familiar with the safe operation of the equipment, operator controls, and safety signs.
- All operators and mechanics should be trained. The owner is responsible for training the users.
- Never let children or untrained people operate or service the equipment. Local regulations may restrict the age of the operator.
- The owner/user can prevent and is responsible for accidents or injuries occurring to people or damage to property.

Preparation

- Evaluate the terrain to determine what accessories and attachments are needed to properly and safely perform the job. Only use accessories and attachments approved by the manufacturer.
- Wear appropriate clothing including safety glasses and hearing protection. Long hair, loose clothing, or jewelry may get tangled in moving parts.
- Inspect the area where the equipment is to be used and remove all objects such as rocks, toys, and wire which can be contacted by the machine.
- Use extra care when handling gasoline and other fuels. They are flammable and vapors are explosive.
 - Use only an approved container.
 - Never remove the gas cap or add fuel with the engine running.
 - Allow the engine to cool before refueling.
 - Do not smoke.
 - Never refuel or drain the machine indoors.
- Check that the operator presence controls, safety switches, and shields are attached and functioning properly. Do not operate unless they are functioning properly.

Operation

- Never run an engine in an enclosed area.

- Only operate in good light, keeping away from holes and hidden hazards.
- Be sure all drives are in neutral before starting engine. Start the engine only from the operator's position.
- Never operate without the shields, covers, or other guards securely in place. Be sure all interlocks are functioning properly.
- Do not change the engine governor setting or overspeed the engine.
- Stop the machine, stop the engine, wait for all moving parts to stop, and raise the blades before leaving the operator's position for any reason.
- Stop the machine and inspect the blades after striking an object or if an abnormal vibration occurs. Make necessary repairs before resuming operation.
- Keep hands and feet away from the blade area.
- Never carry passengers and keep pets and bystanders away.
- Be alert, slow down, and use caution when making turns. Look behind and to the side before changing directions.
- Slow down and use caution when crossing roads and sidewalks.
- Do not operate the machine under the influence of alcohol or drugs.
- Lightning can cause severe injury or death. If lightning is seen or thunder is heard in the area, do not operate the machine; seek shelter.
- Use extreme care when loading or unloading the machine into a trailer or truck.
- Use care when approaching blind corners, shrubs, trees, or other objects that may obscure vision.
- Always be aware of obstacles that may be in the area of operation. Plan your path to avoid contact with any obstacle by you or the machine.

Slope Operation

- Do not operate near drop-offs, ditches, steep banks, or water. Wheels dropping over edges can cause rollovers, which may result in serious injury or death.
- Do not operate on slopes when grass is wet. Slippery conditions reduce traction and could cause sliding and loss of control.
- Do not make sudden turns or rapid speed changes.
- Reduce speed and use extreme caution on slopes.
- Remove or mark obstacles such as rocks, tree limbs, and other objects from the operating area. Tall grass can hide obstacles.
- Watch for ditches, holes, rocks, dips, and rises that change the operating angle, as rough terrain could overturn the machine.
- Always avoid sudden starting or stopping on a slope. If the tires lose traction, disengage the blades and proceed slowly off the slope.

Maintenance and Storage

- Stop the machine, stop the engine, wait for all moving parts to stop, raise the blades, and disconnect the spark-plug wire before adjusting, cleaning, or repairing.
 - Clean grass and debris from the blades, drives, muffler, and engine to help prevent fires. Clean up oil or fuel spillage.
 - Let the engine cool before storing and do not store near flame.
 - Shut off the fuel while storing or transporting on trailers. Do not store fuel near flames or drain indoors.
 - Park the machine on level, hard ground. Never allow untrained personnel to service it.
- Use jack stands or safety latches to support components when required.
 - Carefully release pressure from components with stored energy.
 - Remove the spark-plug wire before making any repairs.
 - Keep hands and feet away from moving parts. If possible, do not make adjustments with the engine running.
 - Keep all parts in good working condition and all hardware tightened. Replace all worn or damaged decals.
 - Use only Toro-approved attachments. The warranty may be voided if the machine is used with unapproved attachments.

Safety and Instructional Decals

Safety decals and instructions are easily visible to the operator and are located near any area of potential danger. Replace any decal that is damaged or lost.

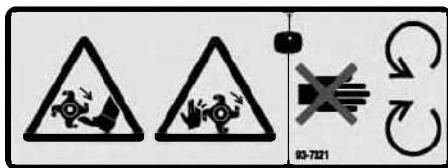

93-7321

1. Cutting/dismemberment hazard of hands and feet, rotating knives/blades—stay away from moving parts.

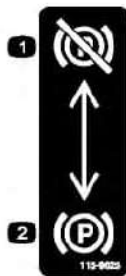

115-9625

1. Parking brake—disengaged
2. Parking brake—engaged

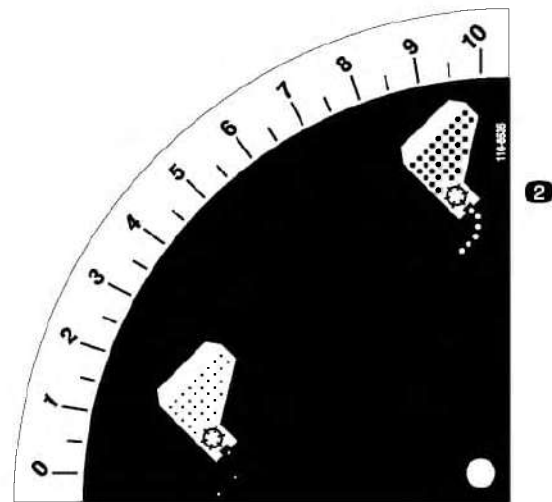

116-8535

1. Lower seed flow rate
2. Higher seed flow rate

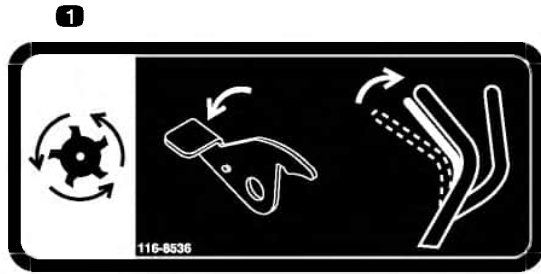

116-8536

1. Cutting blades - press down on lever and pull blade control bail against the handle to engage the cutting blades.

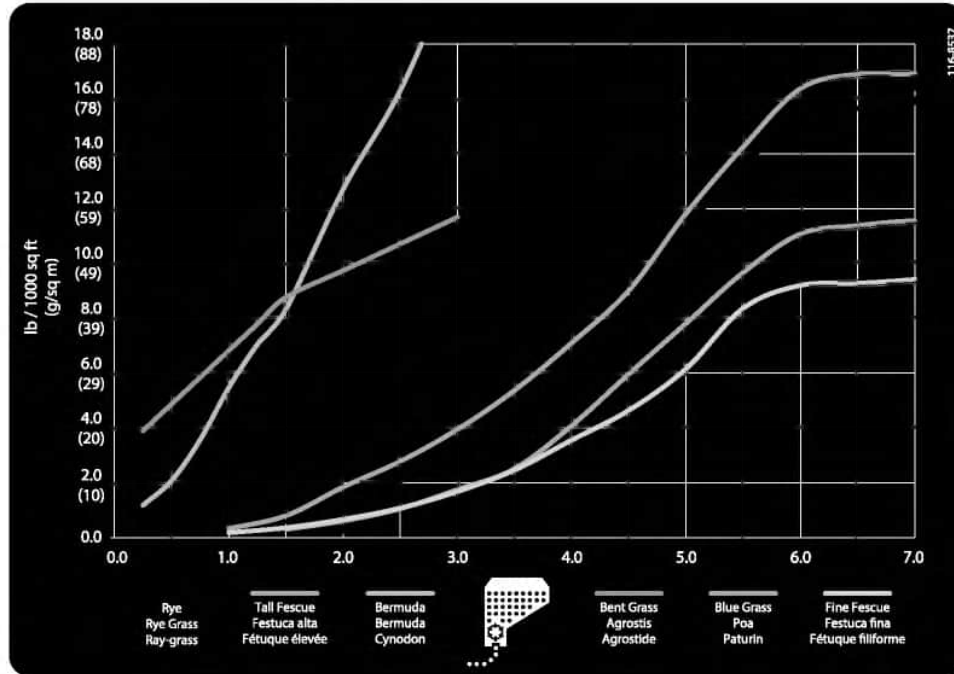

116-8537



116-8648

1. To start the engine, read the Operator's manual - (1) Park the machine on a level surface (2) Fill the engine with oil (3) Move the control bars to a neutral position (4) Start the engine.
2. Self-propel drive - push the self-propel drive bail forward to move the machine forward; pull the self-propel drive bail downward to move the machine backward.
3. Cutting blades - release the blade control bail (neutral position) to disengage the cutting blades; hold the blade control bail against the handle to engage the cutting blades.
4. Seed hopper on; seed hopper off.

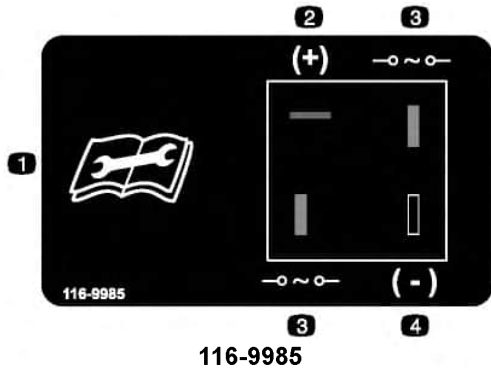

116-9985

- | | |
|---|---|
| 1. Read and understand the operator's manual before servicing this machine. | 3. AC terminal - orange wire connects to engine harness |
| 2. Positive terminal - red and blue wires | 4. Negative terminal - black wire |

CALIFORNIA SPARK ARRESTER WARNING
 Operation of this equipment may create sparks that can start fires around dry vegetation. A spark arrester may be required. The operator should contact local fire agencies for laws or regulations relating to fire prevention requirements. 117-2718

117-2718

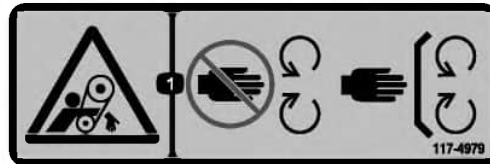

117-4979

1. Entanglement hazard, belt—keep away from moving parts; keep all guards and shields in place.

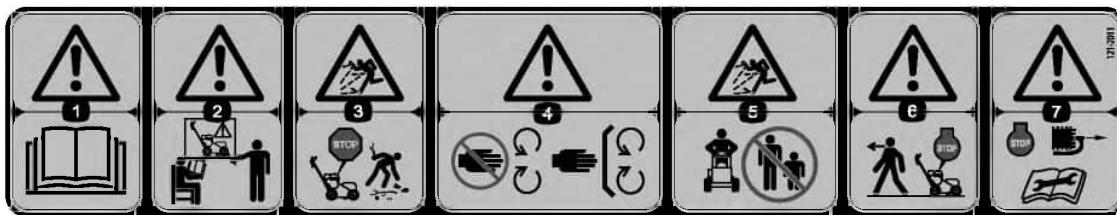

121-2011

- | | | | |
|--|---|---|---|
| 1. Warning—read the <i>Operator's Manual</i> . | 3. Thrown object hazard; pick up debris before operating. | 5. Thrown object hazard—keep bystanders a safe distance from the machine. | 7. Warning—stop the engine and remove the spark plug wire before performing any maintenance on the machine. |
| 2. Warning—do not operate this machine unless you are trained. | 4. Warning—keep hands away from moving parts, keep all guards and shields in place. | 6. Warning—stop the engine before leaving the machine. | |



121-6203

- | | |
|--|-------------------------------|
| 1. Bypass lever position for operating the machine | 3. Read the Operator's manual |
| 2. Bypass lever position for pushing the machine | |

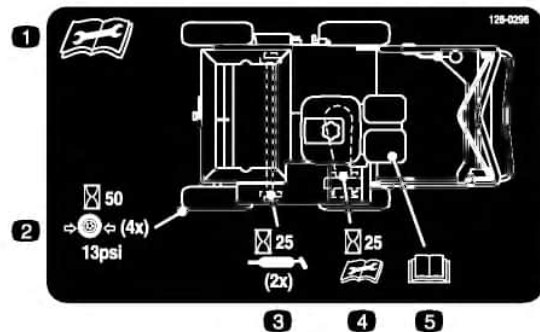

126-0296

- | | |
|--|---|
| 1. Read and understand the operator's manual before servicing this machine | 4. Check transmission belt drive tension every 25 hours |
| 2. Check tire pressure - 13 psi (4x) every 50 hours | 5. See engine owner's manual for service |
| 3. Grease the slicer shaft bearings every 25 hours | |

Setup

Unfolding the Handle

1. Raise the handle to the operating position (Figure 3).

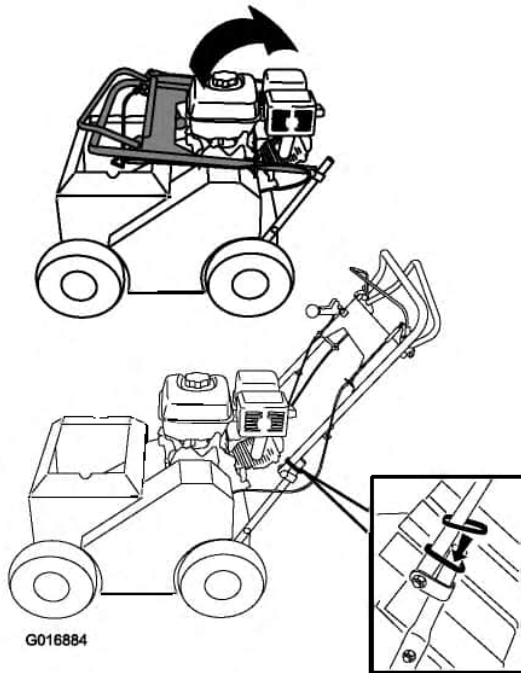

Figure 3

2. Slide the oval locking rings down each side of the upper handle and over the lower handle (Figure 3), locking the handle sections together.

Checking the Engine Oil Level

Refer to Checking the Engine Oil Level (page 11).

Product Overview

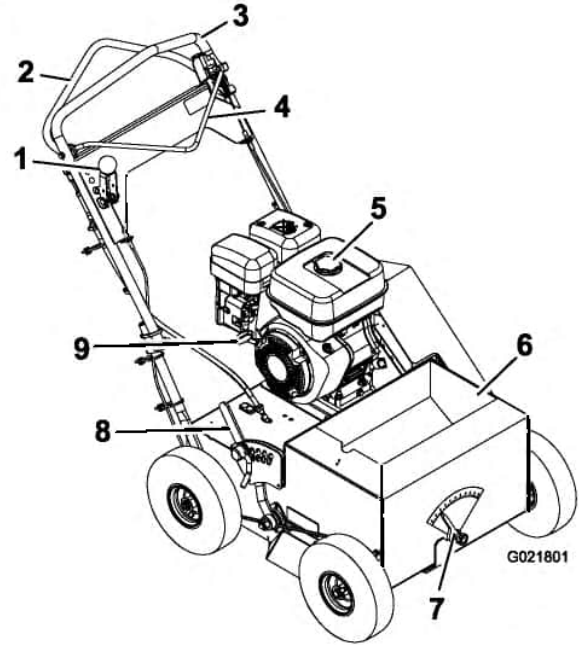

Figure 4

- | | |
|---------------------------|------------------------|
| 1. Seeder-control lever | 6. Seed hopper |
| 2. Self-propel drive bail | 7. Seeding-rate gauge |
| 3. Handle | 8. Depth-control lever |
| 4. Blade-control bail | 9. Recoil-start handle |
| 5. Fuel-tank cap | |

for a few days, during transport to and from the jobsite, and when parked inside a building.

Rotate it down to open it or up to close it.

Self-propel Drive Bail

The self-propel drive bail (Figure 6), located under the handle, controls the forward and reverse motion of the machine.

When you squeeze the self-propel drive bail is against the handle, the ground speed of the machine will change based on the distance between the bail and the handle. When you release the bail, the machine will stop moving.

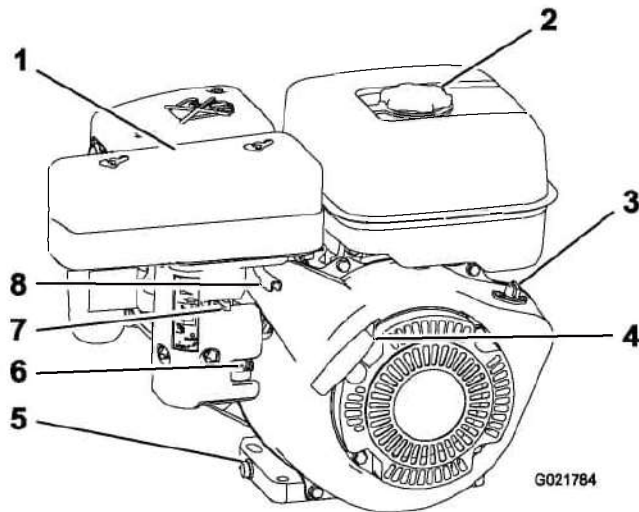

Figure 5

- | | |
|------------------------|-----------------------|
| 1. Air cleaner | 5. Oil-drain plug |
| 2. Fuel-tank cap | 6. Fuel shutoff valve |
| 3. On/off switch | 7. Choke lever |
| 4. Recoil-start handle | 8. Throttle lever |

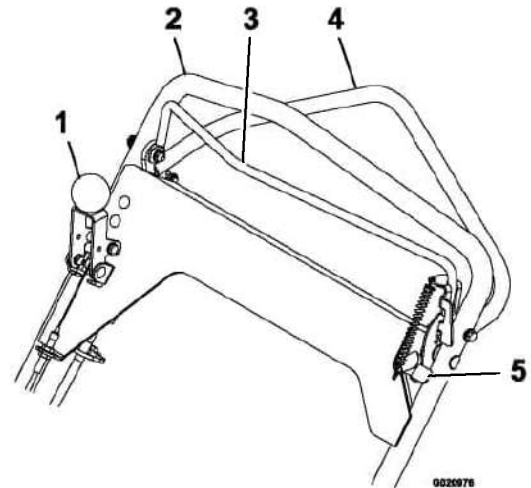

Figure 6

- | | |
|-------------------------|---------------------------|
| 1. Seeder-control lever | 4. Self-propel drive bail |
| 2. Handle | 5. Blade-control lock |
| 3. Blade-control bail | |

Controls

Choke Lever

Before starting a cold engine, move the choke lever (Figure 5) to the left. After the engine starts, regulate the choke to keep the engine running smoothly. As soon as possible, move the choke lever all the way to the right.

Note: A warm engine requires little or no choking.

Throttle Lever

The throttle lever (Figure 5) is located on the engine and controls the engine speed. Moving the throttle lever rearward increases the engine speed, and moving the throttle lever forward decreases the engine speed.

Engine On/Off Switch

The engine on/off switch (Figure 5) is located on the front right-hand side of the engine. Rotate the switch clockwise to the On position before starting the engine. Rotate the switch counterclockwise to the Off position to stop the engine.

Fuel Shutoff Valve

The fuel shutoff valve (Figure 5) is located on the engine and is used to shut off the fuel when the machine will not be used.

Blade-control Bail

The blade-control bail (Figure 6), located in front of the handle, engages or disengages the blade.

If the engine is running, the blades will engage when you squeeze the blade-control bail toward the handle.

When you release the blade-control bail, the blades will stop.

Blade-control Lock

The blade-control lock (Figure 6) is located on the left side of the handle, next to the blade-control bail.

Moving the blade-control lock into the full forward position allows the blade-control bail to be squeezed against the handle.

Squeezing the blade-control bail against the handle engages the blade. Releasing the blade-control bail automatically disengages the blade. The blade-control lock will reset to lock the blade-control bail.

Seeder-control Lever

The seeder-control lever (Figure 6) is located on the right handle bar.

Push the lever forward to start the seed flow, and pull it rearward to stop the seed flow.

Parking Brake

Set the parking brake whenever you leave the machine unattended and when performing maintenance. To engage the parking brake, pull the brake rod out and down, locking it in the out position. To disengage the brake, pull the brake up until it snaps back into the machine.

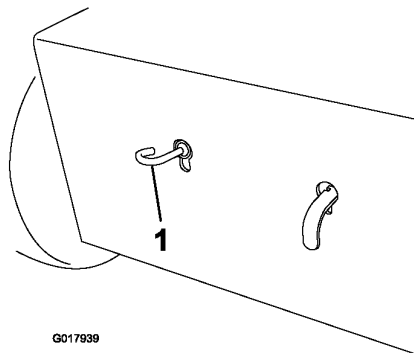

Figure 7
(Rear of machine shown)

1. Parking brake

Hydrostatic-drive Bypass Lever

The hydrostatic-drive bypass lever (Figure 8) releases the hydrostatic-drive system so you can move the machine by hand, without the engine running.

For normal operating position, pull up on the handle and push the handle in until all 3 notches are inside the frame.

Note: The last notch on the handle does not latch on the slot.

To release the drive wheels, pull up on the handle and pull it out until the last notch engages in the slot. Then push the handle down.

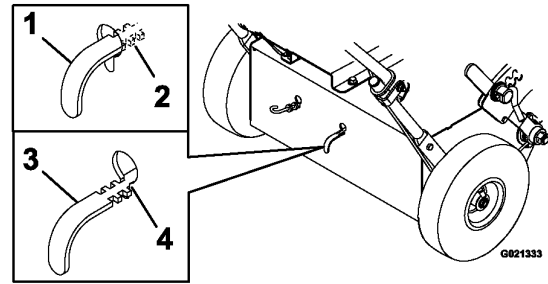

Figure 8

1. Handle in—normal operating position
2. All notches inside frame
3. Handle out—hydrostatic-drive release
4. Last notch engaged in slot

Specifications

Note: Specifications and design are subject to change without notice.

Width	76 cm (30 inches)
Length (operating)	137 cm (54 inches)
Length (with handle stored)	95.25 cm (37.5 inches)
Height (operating)	113 cm (44.5 inches)
Height (with handle stored)	73.5 cm (29 inches)
Weight	120.2 kg (265 lb)

Torque Requirements

Bolt Location	Torque
Engine mounting bolts	37 to 45 N-m (27 to 33 ft-lb)
Clutch mounting bolts	66 to 83 N-m (49 to 61 ft-lb)
Slicer shaft nut	88 to 115 N-m (65 to 85 ft-lb)

Attachments/Accessories

Approved attachments and accessories are available for use with the machine to enhance and expand the capabilities of the machine. Contact an Authorized Service Dealer or Distributor or go to www.Toro.com for a list of all approved attachments and accessories.

Operation

Note: Determine the left and right sides of the machine from the normal operating position.

Checking the Engine Oil Level

Service Interval: Before each use or daily

Toro Premium Engine Oil is available from your Authorized Toro Dealer.

Important: Use 4-cycle *detergent* engine oil that meets or exceeds the requirements for API service category *SJ, SL, SM, or higher*.

Crankcase Capacity: 1.0 L (1.06 US qt)

Important: If the oil level in the crankcase is too low or too high and you run the engine, you may damage the engine. This type of damage is not covered by the warranty.

Note: Use SAE 10W-30 for general use. You can use the other viscosities shown in the chart when the average temperature in your area is within the indicated range (Figure 9).

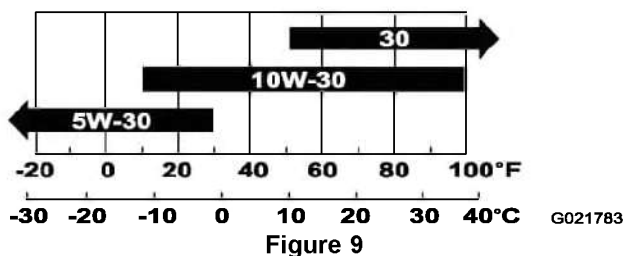

Figure 9

1. Stop the machine on a level surface, and ensure that the engine is level.
2. Disengage the cutting blades, stop the engine, wait for all moving parts to stop, and turn the engine switch to the Off position.
3. Allow the engine to cool.
4. Clean around the dipstick (Figure 10) so that dirt cannot fall into the fill hole and damage the engine.

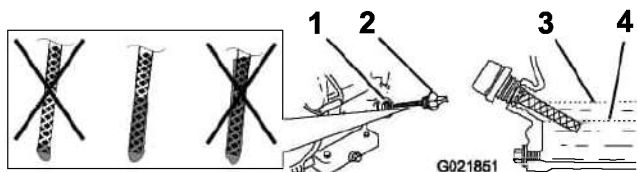

Figure 10

1. Fill hole
2. Dipstick
3. Upper level
4. Lower level

5. Remove the dipstick, and wipe the end clean.

6. Insert the dipstick fully into the fill hole, but **do not screw it in** (Figure 10).
7. Remove the dipstick again and look at the end. If the engine oil level is low, slowly pour only enough oil into the fill hole to raise the level to the Full mark on the dipstick (Figure 10).

Adding Fuel

- For best results, use only clean, fresh, unleaded gasoline with an octane rating of 87 or higher (rating method: $(R+M)/2$).
- Oxygenated fuel with up to 10% ethanol or 15% MTBE by volume is acceptable.
- **Do not** use ethanol blends of gasoline (such as E15 or E85) with more than 10% ethanol by volume. Performance problems and/or engine damage may result which may not be covered under warranty.
- **Do not** use gasoline containing methanol.
- **Do not** store fuel either in the fuel tank or fuel containers over the winter unless a fuel stabilizer is used.
- **Do not** add oil to gasoline.

⚠ DANGER

In certain conditions, gasoline is extremely flammable and highly explosive. A fire or explosion from gasoline can burn you and others and can damage property.

- Fill the fuel tank outdoors, in an open area, when the engine is cold. Wipe up any gasoline that spills.
- Never fill the fuel tank inside an enclosed trailer.
- Do not fill the fuel tank completely full. Add gasoline to the fuel tank until the level is 6 to 13 mm (1/4 to 1/2 inch) below the bottom of the filler neck. This empty space in the tank allows gasoline to expand.
- Never smoke when handling gasoline, and stay away from an open flame or where gasoline fumes may be ignited by a spark.
- Store gasoline in an approved container and keep it out of the reach of children. Never buy more than a 30-day supply of gasoline.
- Do not operate without the entire exhaust system in place and in proper working condition.

⚠ DANGER

In certain conditions during fueling, static electricity can be released, causing a spark which can ignite the gasoline vapors. A fire or explosion from gasoline can burn you and others and can damage property.

- Always place gasoline containers on the ground away from your vehicle before filling.
- Do not fill gasoline containers inside a vehicle or on a truck or trailer bed, because interior carpets or plastic truck-bed liners may insulate the container and slow the loss of any static charge.
- When practical, remove fuel-powered equipment from the truck or trailer, and fuel the equipment with the wheels on the ground. If this is not possible, then refuel such equipment on a truck or trailer from a portable container rather than from a gasoline dispenser nozzle.
- If a fuel-dispenser nozzle must be used, keep the nozzle in contact with the rim of the fuel tank or container opening at all times until fueling is complete.

⚠ WARNING

Fuel is harmful or fatal if swallowed. Long-term exposure to vapors can cause serious injury and illness.

- Avoid prolonged breathing of vapors.
- Keep your face away from the nozzle and the fuel tank or conditioner opening.
- Keep fuel away from your eyes and skin.

Important: Do not mix oil with fuel.

Recommended Fuel

Unleaded Gasoline	
U.S.	Pump octane rating 87 or higher
Except U.S.	Research octane rating 92 or higher Pump octane rating 87 or higher

Using Fuel Stabilizer/Conditioner

Use a fuel stabilizer/conditioner in the machine to keep the fuel fresh during storage of 90 days or less. If you are storing the machine for longer, drain the fuel tank; refer to Emptying the Fuel Tank (page 20).

Important: Do not use fuel additives containing methanol or ethanol.

Add the correct amount of fuel stabilizer/conditioner to the fuel, and follow the directions of the manufacturer.

Note: Fuel stabilizer/conditioner is most effective when mixed with fresh fuel. To minimize the chance of varnish deposits in the fuel system, use fuel stabilizer at all times.

Filling the Fuel Tank

Capacity: 5.6 L (1.48 US gallons)

1. Disengage the cutting blades, stop the engine, wait for all moving parts to stop, and turn the engine switch to the Off position.
2. Allow the engine to cool.
3. Clean around the fuel-tank cap and remove it.

Note: The cap is tethered to the fuel tank.

4. Add unleaded gasoline to the fuel tank until the level is just inside the mesh filter basket.

Important: This space in the tank allows gasoline to expand. Do not fill the fuel tank completely full.

5. Install the fuel-tank cap securely.
6. Wipe up any spilled gasoline.

Starting and Stopping the Engine

Starting the Engine

1. Ensure that the blade-control bail is in the off position.
2. Move the engine switch to the On position, and open the fuel shutoff valve.
3. Move the choke lever to the left if you are starting a cold engine.

Note: A warm or hot engine may not require choking

4. Move the throttle lever midway between the slow (turtle) and fast (rabbit) positions.
5. Pull the recoil-start handle sharply to start the engine.
6. After the engine starts, gradually move the choke to the right.

Note: If the engine stalls or hesitates, move the choke left again until the engine warms up.

7. Move the throttle lever to the desired setting.

Stopping the Engine

1. Bring the machine to a full stop.
2. Release the blade-control bail. The blades should stop; the engine will continue to run.
3. Place the throttle midway between the Slow and Fast positions.
4. Allow the engine to run for a minimum of 15 seconds, then turn the engine on/off switch to the Off position to stop the engine.

Important: In an emergency situation, stop the engine immediately.

5. Close the fuel shutoff valve.
6. Wait for all moving parts to stop before proceeding.

Operating the Self-propel Drive

1. Start the engine.
2. Move the self-propel drive bail from the neutral position.
 - To move forward, squeeze the self-propel drive bail against the handle (Figure 11).

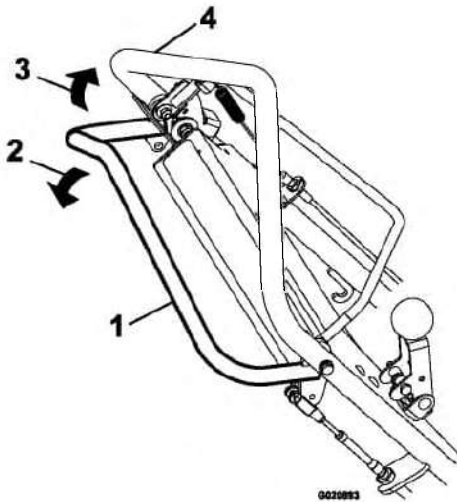

Figure 11

- | | |
|---|-----------------------------------|
| 1. Self-propel drive bail (neutral position) | 3. Forward—pull toward the handle |
| 2. Reverse—push down and away from the handle | 4. Handle |

Note: You can vary the ground speed by increasing or decreasing the distance between the self-propel drive bail and the handle. Lower the drive bail toward the neutral position to decrease the ground speed when making a turn or if the machine is moving too fast. If you release the drive bail, it returns to neutral and the machine stops moving. Squeeze the drive bail closer to the handle to increase the ground speed. When you hold the drive bail tight against the handle, the machine moves at the maximum ground speed. Release the drive bail to stop moving or whenever you leave the machine.

- To turn left or right, decrease the speed, push down on the handles, and turn the machine in the desired direction; then resume normal operation.
- To move in reverse, release the drive bail and allow it to return to neutral. Push the drive bail down

and away from the handle. The ground speed will vary as the distance increases or decreases from the neutral position.

3. To disengage the self-propel drive and place the machine into the neutral position, release the drive bail.

Note: If the machine creeps forward or rearward when the drive bail is in the neutral position, stop the engine and adjust the self-propel drive cable; refer to Adjusting the Self-propel Drive (page 21).

Operating the Blade-control Bail

1. Start the engine.
2. Push and hold the blade-control lock forward to release the blade-control bail (Figure 12).

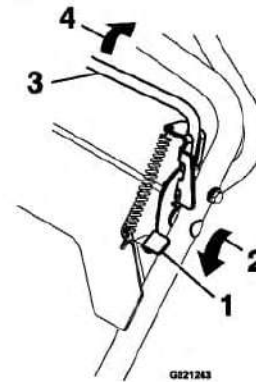

Figure 12

- | | |
|---|---------------------------|
| 1. Blade-control lock (locked position) | 3. Blade-control bail |
| 2. Push | 4. Squeeze against handle |

3. Squeeze the blade-control bail against the handle and release the blade-control lock; the blades will engage.
4. Release the blade-control bail to disengage the blades. The blade-control lock will reset to lock the blade-control bail.

Operating the Machine

⚠ DANGER

The rotating blades under the machine are dangerous. Blade contact can cause serious injury or death.

Do not put hands or feet under the machine.

⚠ DANGER

When the machine is in operation, contact with rotating or moving parts will severely injure hands and feet.

- Before adjusting, cleaning, inspecting, troubleshooting, or repairing the machine, stop the engine and wait for all moving parts to stop. Disconnect the wire from the spark plug and keep it away from the plug to prevent someone from accidentally starting the engine.
- Stay behind the handle and away from the seed mixer and cutting blades while operating the machine.
- Keep face, hands, feet, and any other part of your body or clothing away from concealed, moving, or rotating parts.

1. If seeding, fill the seed hopper and set the seeding rate gauge; refer to Adjusting the Seeding-rate Gauge (page 14).
2. Adjust the cutting-blade depth to the desired setting; refer to Adjusting the Cutting-blade Depth (page 14).
3. Start the engine.
4. Set the engine throttle to the Fast position.
5. Push down on the handle to raise the front wheels slightly off the ground.
6. Squeeze the blade-control bail against the handle to engage the blades. Slowly lower the front wheels to the ground, allowing the blades to gradually work into the grass and soil.
7. If seeding, push the seeder-control lever forward to start the seed flow.

Note: There is no need to turn the seeder-control lever off and on for each turn. The seed flow will slow and/or stop when the machine is stopped or slowed for turning. To reduce seed loss, raise the front wheels as the machine is turned.

Note: The machine will seed at the same rate going forward or rearward.

Note: If there is excessive thatch, it may be necessary to remove the thatch prior to seeding.

8. Engage the self-propel drive bail to begin operating.

Adjusting the Cutting-blade Depth

1. Bring the machine to a full stop.
2. Disengage the cutting blades.

3. Stop the engine and wait for all moving parts to stop before leaving the operating position. Disconnect the wire from the spark plug.
4. Unlock the cutting-blade depth handle by pulling upward.

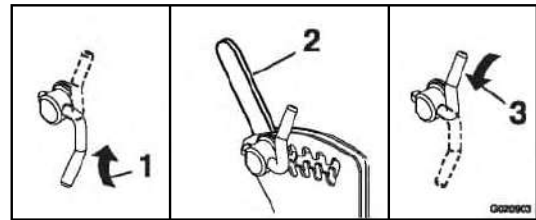

Figure 13

1. Unlock
2. Cutting-blade depth handle
3. Lock

5. Move the lever to the desired working depth slot setting. Rotate and push the handle down to lock the handle.
6. The setting will need to be adjusted as the cutting blades wear.

Adjusting the Seeding-rate Gauge

1. Bring the machine to a full stop.
2. Disengage the cutting blades.
3. Stop the engine and wait for all moving parts to stop before leaving the operating position.
4. To change the seeding rate, loosen the knob on the seeding-rate gauge located on the front of the seed hopper. Move the gauge pointer to the desired position, and tighten the knob.

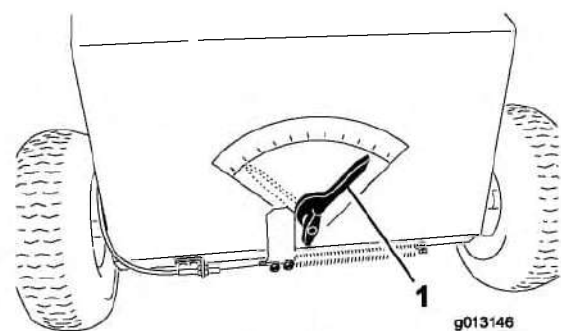

Figure 14

1. Gauge pointer

Note: Refer to the seeding graph, located on the machine, to determine the correct gauge setting for the type of grass and the thickness to be planted.

Checking the Seed Gate

Service Interval: Before each use or daily

Note: Trapped debris may prevent the seed gate from moving freely.

1. Stop the engine, wait for all moving parts to stop, and remove the spark-plug wire. Engage the parking brake.
2. Check to verify that the seed gate moves freely and is clear of debris.
3. If the seed gate does not open to the stop when the seeder-control lever is in the On position, clean the gate assembly; refer to Cleaning the Seed Gate (page 26).

Operating Tips

Overseeding

- Set the cutting blades to be 3 to 6 mm (1/8 to 1/4 inch) into the earth.
- As seed flow varies greatly between different seed types, fill the hopper with a minimal amount of seed and run a trial portion of the yard to ensure you have the desired seed output.
- For optimal coverage, reduce the seed flow to 1/2 the desired amount and seed the entire yard in one direction, then complete a second coverage perpendicular to the first.

Important: Do not put down more seed than recommended by the seed company. Overseeding can cause the grass to be too thick and cause it to be susceptible to fungus.

Dethatching

Set the cutting blades to be 3 to 6 mm (1/8 to 1/4 inch) past the thatch layer, into the earth. Operate the machine over the yard with the seeder-control lever turned off.

Power Raking/Renovating

To break new ground or till an existing lawn, set the cutting blades to be 6 to 13 mm (1/4 to 1/2 inch) into the earth. Go forward and backward over the area to be leveled, or make multiple passes from different directions.

The machine will work best when the ground is hard and dry and will be most aggressive in breaking up the soil in reverse. If the ground is soft and causes the engine to bog down, raise the blades a bit and make a few passes before lowering them to the full depth.

Transporting the Machine

▲ WARNING

Loading the machine onto a trailer without strong enough or properly supported ramps could be dangerous. The ramps could collapse, causing the machine to fall, which could cause injury.

- **Use proper ramps that are secured to the truck or trailer.**
- **Keep feet and legs out from under the machine when loading and unloading.**
- **If necessary, use assistance when loading.**

Be sure that the fuel shutoff valve is closed.

Securely fasten the machine to the trailer with straps, chains, cables, or ropes.

Be sure that the trailer has all necessary lighting and marking as required by law, and use safety chains.

Maintenance

Recommended Maintenance Schedule(s)

Maintenance Service Interval	Maintenance Procedure
After the first 5 hours	<ul style="list-style-type: none"> • Change the engine oil.
Before each use or daily	<ul style="list-style-type: none"> • Check the engine oil level. • Check the seed gate. • Inspect the air-cleaner elements. • Check the tire pressure. • Check the blades for wear or damage. • Clean the engine and exhaust area. • Clean the debris buildup from under the machine. • Check for loose fasteners.
Every 25 hours	<ul style="list-style-type: none"> • Grease the slicer-shaft bearings. • Check the condition of the belts.
Every 50 hours	<ul style="list-style-type: none"> • Clean the air-cleaner elements. Clean them more frequently in dusty operating conditions. • Change the engine oil. • Check the spark arrester (if equipped). • Clean under the belt cover.
Every 100 hours	<ul style="list-style-type: none"> • Inspect and adjust the spark plug; replace it if necessary. • Change the hydraulic-transmission fluid.
Every 200 hours	<ul style="list-style-type: none"> • Replace the paper air-cleaner element. Replace it more frequently in dusty operating conditions. • Replace the spark plug.
Yearly or before storage	<ul style="list-style-type: none"> • Touch up chipped paint.

Premaintenance Procedures

Disengaging the Hydrostatic Drive

If you need to push the machine unpowered, you must release the hydrostatic drive. To release the drive, pull the hydrostatic-drive bypass lever (Figure 15) out and down, locking it in the out position. The front wheels will now rotate.

To engage the drive, pull up on the bypass lever until it snaps back into the machine.

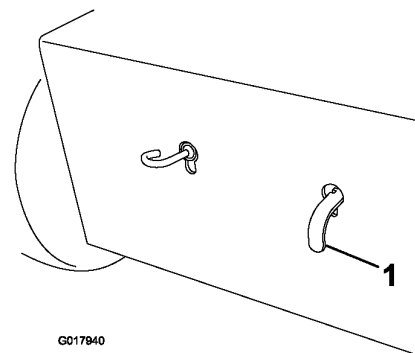

Figure 15
(Rear of machine shown)

1. Hydrostatic-drive bypass lever

Disconnecting the Spark-plug Wire

Before performing any maintenance on the engine, belt, or cutting blades, disconnect the spark-plug wire from the spark plug (Figure 16).

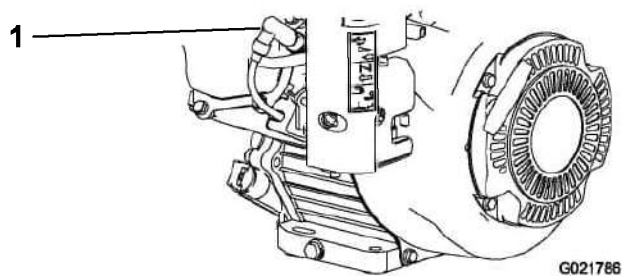

Figure 16

1. Spark-plug wire
-

Lubrication

Lubricating the Slicer-shaft Bearings

Service Interval: Every 25 hours—Grease the slicer-shaft bearings.

1. Stop the engine, wait for all moving parts to stop, and remove the spark-plug wire.
2. Engage the parking brake.
3. Lubricate the fittings (Figure 17) with 1 or 2 pumps of NLGI grade #2 multi-purpose grease.

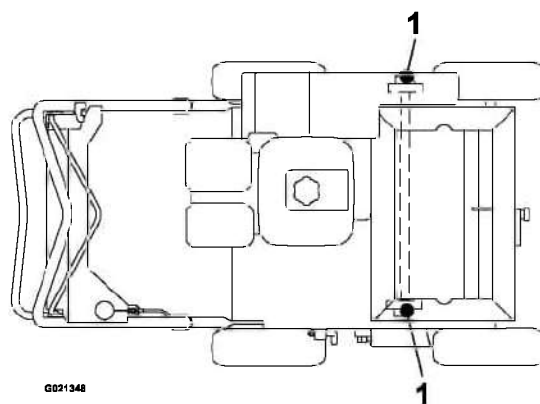

Figure 17

1. Grease fitting
-

Engine Maintenance

Servicing the Air Cleaner

Service Interval: Before each use or daily—Inspect the air-cleaner elements.

Every 50 hours—Clean the air-cleaner elements. Clean them more frequently in dusty operating conditions.

Every 200 hours/Monthly (whichever comes first)—Replace the paper air-cleaner element. Replace it more frequently in dusty operating conditions.

Important: Do not operate the engine without the air filter assembly; extreme engine damage will occur.

1. Stop the engine and wait for all moving parts to stop.
2. Disconnect the wire from the spark plug.
3. Remove the wing nuts that secure the cover (Figure 18).

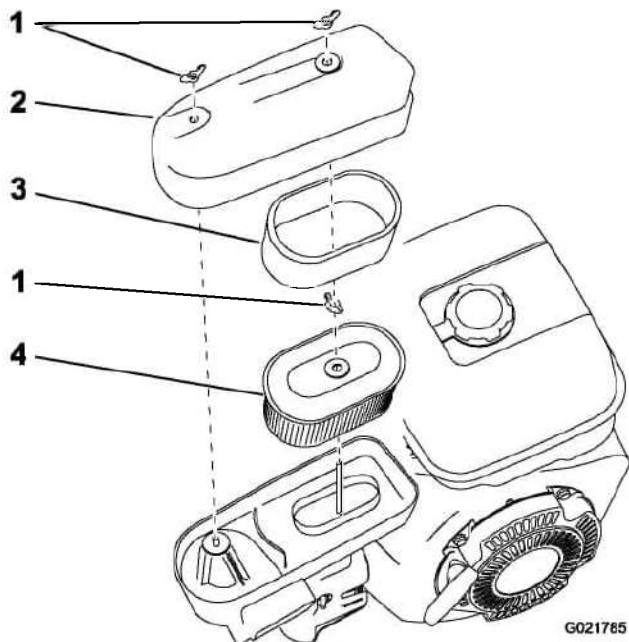

Figure 18

- | | |
|-------------|------------------|
| 1. Wing nut | 3. Foam element |
| 2. Cover | 4. Paper element |

4. Remove the cover.

Note: Be careful to prevent dirt and debris from falling into the base.

5. Remove the nut restraining the air filter assembly.
6. Remove the foam and paper elements from the base (Figure 18).
7. Remove the foam element from the paper element (Figure 18).

8. Inspect the foam and paper elements, and replace them if they are damaged or excessively dirty.

9. Clean the paper element by tapping it gently to remove the dirt.

Note: Never try to brush dirt off the paper element; brushing forces the dirt into the fibers. Replace the element if tapping it fails to remove the dirt.

10. Clean the foam element in warm, soapy water or in a **nonflammable** solvent.

Note: Do not use gasoline to clean the foam element because it could create a risk of fire or explosion.

11. Rinse and dry the foam element thoroughly.
12. Wipe dirt from the base and the cover with a moist rag.

Note: Be careful to prevent dirt and debris from entering the air duct leading to the carburetor.

13. Install the air-cleaner elements and ensure that they are properly positioned.
14. Secure the air-cleaner elements with the previously removed nut.
15. Securely install the cover with the previously removed nuts.

Servicing the Engine Oil

Service Interval: After the first 5 hours

Every 50 hours

Toro Premium Engine Oil is available from your Authorized Toro Dealer.

Important: Use 4-cycle detergent engine oil that meets or exceeds the requirements for API service category *SJ, SL, SM, or higher.*

Crankcase Capacity: 1.0 L (1.06 US qt)

Important: If the oil level in the crankcase is too low or too high and you run the engine, you may damage the engine. This type of damage is not covered by the warranty.

Note: Use SAE 10W-30 for general use. You can use the other viscosities shown in the chart when the average temperature in your area is within the indicated range (Figure 19).

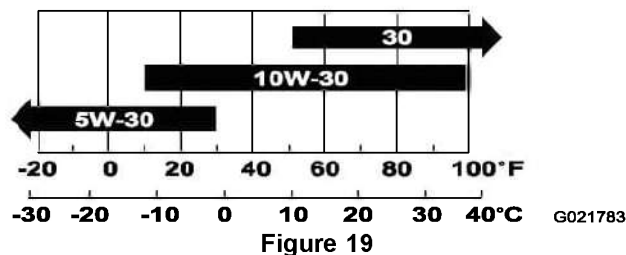

Figure 19

Changing the Engine Oil

⚠ WARNING

Oil may be hot after the engine has been run, and contact with hot oil can cause severe personal injury.

Avoid contacting the hot engine oil when you drain it.

1. Disengage the cutting blades, stop the engine, turn off the engine switch, and wait for all moving parts to stop.
2. Disconnect the wire from the spark plug.
3. Raise the front wheels 5 to 8 centimeters (2 to 3 inches) off the ground, and place a pan under the drain plug to catch the oil.
4. Remove the drain plug (Figure 20).

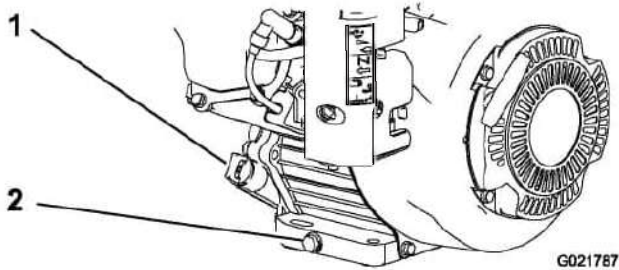

Figure 20

1. Dipstick
2. Drain plug

5. When the oil has drained completely, lower the front wheels to the ground, replace the drain plug, and torque the plug to 18 N·m (13 ft·lb).

Note: Dispose of the used oil at a certified recycling center.

6. Remove the dipstick, and slowly pour oil into the fill hole until the oil pours out of the fill hole.
7. Replace and secure the dipstick.
8. Wipe up any spilled oil.
9. Connect the wire to the spark plug.

Servicing the Spark Plug

Service Interval: Every 100 hours—Inspect and adjust the spark plug; replace it if necessary.

Every 200 hours—Replace the spark plug

Use an **NGK BR6HS** spark plug or equivalent.

1. Stop the engine and wait for all moving parts to stop.
2. Disconnect the wire from the spark plug.
3. Clean around the spark plug.
4. Remove the spark plug from the cylinder head.

Important: Replace a cracked, fouled, or dirty spark plug. Do not clean the electrodes, because grit entering the cylinder can damage the engine.

5. Set the gap on the plug to 0.6 to 0.7 mm (0.024 to 0.028 inch); refer to Figure 21.

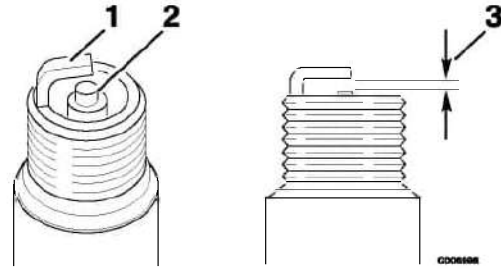

Figure 21

1. Side electrode
2. Center electrode insulator
3. Air gap—0.6 to 0.7 mm (0.024 to 0.028 inch)

6. Carefully install the spark plug by hand (to avoid cross threading) until it is hand tight.
7. Tighten the spark plug an additional 1/2 turn if it is new; otherwise, tighten it an additional 1/8 to 1/4 turn.

Important: A loose spark plug can become very hot and can damage the engine; overtightening a spark plug may damage the threads in the cylinder head.

8. Connect the wire to the spark plug.

Checking the Spark Arrester (if equipped)

Service Interval: Every 50 hours

Note: A spark arrester is available as an option. If you require a spark arrester, contact your Authorized Toro Service Dealer.

Toro spark arresters are approved by the USDA Forestry Service.

⚠ WARNING

If the engine has been running, the muffler will be hot.

1. Stop the engine and wait for all moving parts to stop.
2. Wait for the muffler to cool.
3. Remove the spark arrester from the exhaust outlet by removing the screws from the muffler cover and exhaust deflector.
4. If there are any breaks or holes in the screen, replace the spark arrester.

5. Use a brush to carefully remove carbon deposits from the spark-arrester screen.
6. Install the spark arrester on the exhaust outlet.

Fuel System Maintenance

Emptying the Fuel Tank

1. Stop the engine and wait for it to cool down. Engage the parking brake.

Note: Drain gasoline from a cold engine only.

2. Disconnect the wire from the spark plug.
3. Close the fuel shutoff valve.
4. Disconnect the fuel line by loosening the tube clamp at the carburetor.
5. Open the fuel valve by turning the lever to the open position.
6. Drain the gasoline completely from the tank and fuel line into an approved fuel container.
7. Close the fuel valve.

Drive System Maintenance

Note: The hydrostatic transmission is factory-filled and sealed. It does not require maintenance. For service, contact your Authorized Service Dealer.

Checking the Tire Pressure

Service Interval: Before each use or daily

Maintain the air pressure in the tires as specified. To get the most accurate reading, check the tires when they are cold.

Pressure: 165 kPa (24 psi)

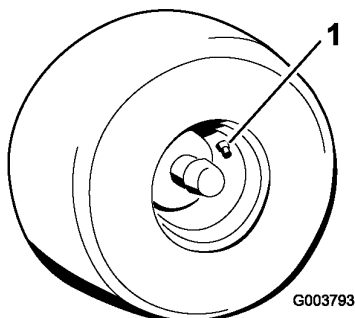

Figure 22

1. Valve stem

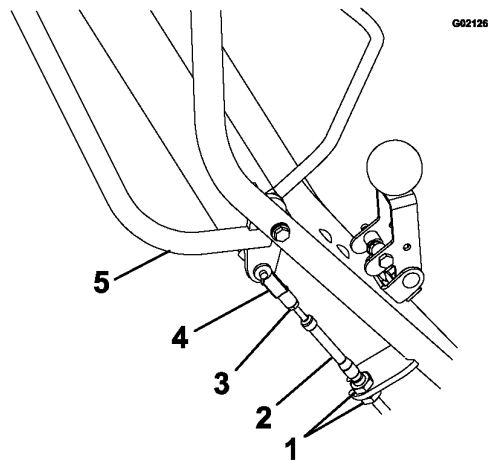

Figure 23

1. Adjustment nuts
2. Cable
3. Jam nut
4. Turnbuckle
5. Self-propel drive bail

- If the bail does not contact the handle, then proceed to step 4.

4. Remove the hairpin and rotate the turnbuckle clockwise 1 full turn.
5. Install the hairpin and rotate the jam nut against the turnbuckle.
6. Start the engine and test the adjustment, repeating this procedure as necessary.

Adjusting the Self-propel Drive

If the machine creeps either forward or rearward when the engine is on and the self-propel drive bail is in neutral, complete the following procedure:

1. Stop the engine, wait for all moving parts to stop, and remove the spark-plug wire.
2. Raise the cutting blades to the highest position.
3. Squeeze the self-propel drive bail to the handle until the transmission is fully stroked.
 - If the bail contacts the handle, release the bail. Loosen the top adjustment nut 1 turn, and tighten the bottom adjustment nut. Squeeze the bail to the handle. Repeat this step until there is a gap of up to 3.2 mm (1/8 inch) between the self-propel drive bail and the handle. Once the gap is achieved, proceed with step 4.

Changing the Hydraulic-transmission Fluid

Service Interval: Every 100 hours

1. Stop the engine, wait for all moving parts to stop, and remove the spark-plug wire. Engage the parking brake.
2. Remove the transmission from the machine.
3. Carefully clean the area around the expansion tank and oil-fill port.

Important: Do not allow any dirt or contamination to enter the hydraulic system.

4. Remove and retain the oil-fill port fitting, and position the transmission so that the oil will drain completely out of the housing.
5. When all the oil has drained from the transaxle, remove and retain the #10-32 x 1/2 inch self-tapping screw and the ratchet fastener holding the expansion tank to the housing.
6. Remove the expansion tank, and drain the oil.

Note: Do not remove the vent cap from the tank.

Note: Do not remove the tank hose or the O-ring unless a replacement is needed.

7. Install the expansion tank by first inserting the hose into the tank. Place the tank opening over the O-ring, and push down to ensure a proper seal. Install the #10-32 x 1/2 inch self-tapping screw and torque it to 25 in-lb (2.8 N-m).
8. Fill the transaxle, at the oil fill port, until the oil level is between 1/2 and 1-1/4 inches (between 13 and 32 mm) below the top of the fill port.

Note: Toro Premium Hydro Oil is recommended. Mobil 1 15W-50 is an acceptable alternative.

9. Reinstall the oil-fill port fitting.

Belt Maintenance

Checking the Condition of the Belts

Service Interval: Every 25 hours

1. Stop the engine, wait for all moving parts to stop, and remove the spark-plug wire. Engage the parking brake.
2. Remove the belt cover from the left side of the machine.
3. Check the belts for cracks, frayed edges, burn marks, or any other damage.
4. If a belt is damaged, replace it.
5. Check the drive-belt tension; refer to Adjusting the Self-propel Drive-belt Tension (page 22).

Adjusting the Self-propel Drive-belt Tension

If the Self-propel drive belt squeals during operation (such as when moved from neutral to forward or reverse), tighten the belt as follows:

1. Stop the engine, wait for all moving parts to stop, and remove the spark-plug wire.
2. Raise the cutting blades to the highest position.
3. Remove and retain the 4 bolts, lock washers, and 2 spacers securing the belt cover to the left side of the machine, and remove the cover.
4. Check the tension of the belt. It should not flex more than a 6 mm (1/4 inch) with moderate finger pressure applied to the span just above the machine frame (Figure 24).

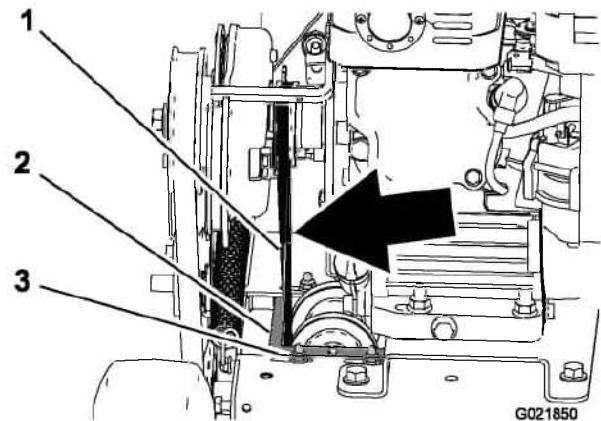

Figure 24

- | | |
|--------------------|--------|
| 1. Belt | 3. Nut |
| 2. Pulley carriage | |

5. To tighten the belt, loosen the 4 mounting nuts and bolts securing the pulley carriage to the frame, and

move the carriage to the left, tightening the belt; then secure the 4 mounting nuts and bolts (Figure 24).

6. Install the belt cover using the hardware retained in step 3.

Maintaining the Cutting Blades

Checking and Replacing the Blades

Service Interval: Before each use or daily—Check the blades for wear or damage.

When the cutting blades are worn down and no longer functioning properly, replace them as follows:

Important: Perform this procedure when the fuel tank is empty or nearly empty.

1. Stop the engine, wait for all moving parts to stop, and remove the spark-plug wire. Engage the parking brake.
2. Turn the fuel shutoff valve to the off position, and drain the fuel from the fuel tank; refer to Emptying the Fuel Tank (page 20).
3. Remove the 4 bolts, lock washers, and 2 spacers securing the belt cover on the left side of the machine, and remove the cover.
4. Remove the blade drive belt from the machine.
5. Tilt the machine rearward until the upper handle rests on the ground, and place a jack stand under the machine.

Note: If necessary, use 2 people to tilt the machine rearward.

⚠ CAUTION

Raising the machine and relying solely on mechanical or hydraulic jacks could be dangerous. The mechanical or hydraulic jacks may not provide enough support or may malfunction allowing the machine to fall, which could cause injury.

Do not rely solely on mechanical or hydraulic jacks for support. Use adequate jack stands or equivalent support.

6. Lower the cutting blades to the lowest position.
7. Spin the cutting blade assembly. It should spin freely. If it makes a grinding noise and is halting, the bearings are worn; replace them when the blades are replaced.
8. Inspect the blades for damage and wear, and replace them as required.

⚠ DANGER

A worn or damaged blade can break. A piece of the blade could be thrown into the area of the operator or a bystander, resulting in serious personal injury or death.

- Inspect the blade periodically for wear or damage.
- Replace a worn or damaged blade.

9. Remove the 4 carriage bolts and locknuts securing the cutting blade assembly (Figure 25), and remove it from the fork mounting bracket.

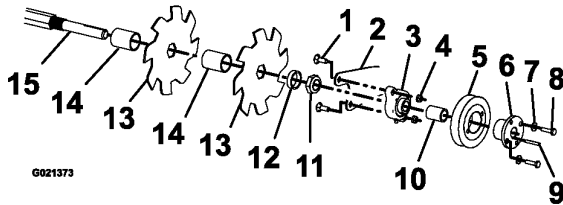

Figure 25

- | | |
|-----------------------------------|-------------------------|
| 1. Carriage bolt | 9. Key |
| 2. Fork mounting bracket | 10. Pulley spacer |
| 3. Flanged bearing with setscrews | 11. Slicer-shaft nut |
| 4. Lock nut | 12. Slicer-shaft spacer |
| 5. Pulley | 13. Cutting blade |
| 6. Tapered hub with setscrews | 14. Blade spacer |
| 7. Washer | 15. Shaft |
| 8. Bolt | |

10. Remove the 2 bolts and washers attaching the pulley to the bearing. Loosen the setscrews on the bearing, and slide the key off the shaft (Figure 25). Remove the bearing and pulley by removing the bearing fasteners from the fork mounting bracket.
11. Loosen the 2 setscrews located on the flanged bearing, and slide the bearing off of the shaft.
12. Loosen and remove the slicer-shaft nut and pulley spacer from the shaft.
13. Carefully slide the alternating blades and spacers off of the shaft, and replace them as necessary.
14. Reverse the procedure to install the assembly.

Note: Rotate each blade 1/6 turn from the previous blade.

⚠ WARNING

Incorrect installation of the blade or components used to retain the blade can be dangerous. Failure to use all original components and assembled as shown could allow a blade or blade component to be thrown out from under the deck resulting in serious personal injury or death.

Always install Toro blades, blade drivers, and blade bolts as shown.

15. Return the machine to the upright position.
16. Connect the wire to the spark plug.

Seed Gate Maintenance

Adjusting the Seed-gate Closed Position

If the seed gate is partially open when the seeder-control lever is in the Off position, complete the following:

1. Stop the engine, wait for all moving parts to stop, and remove the spark-plug wire.
2. Raise the cutting blades to the highest position.
3. Pull the seeder-control lever to the Off position.
4. Loosen the nuts on the seed-gate control cable (see Figure 26).

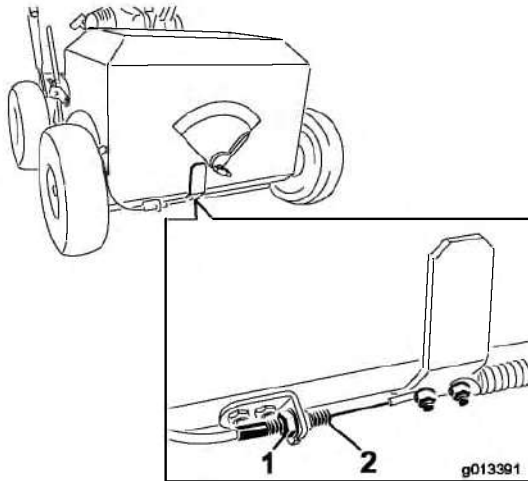

Figure 26

1. Jam nut

2. Cable

5. Move the cable right to close the seed gate or left to open it.

Important: Do not tighten the cable to the point the seed gate is tight to the right with extreme tension on the cable as this will damage the gate and the cable. Only adjust it until the openings in the bottom of the seeder are closed.

6. Tighten the jam nuts and test the seeder-control lever to ensure that the seed gate opens and closes correctly.

Cleaning

Cleaning the Engine Area

Service Interval: Before each use or daily (Clean the engine and exhaust area more often in dry or dirty conditions.)

⚠ CAUTION

Excessive debris around engine and exhaust area can cause engine and exhaust area to overheat, which can create a fire hazard.

Clean all debris from engine and exhaust area.

1. Stop the engine, wait for all moving parts to stop, and remove the spark-plug wire.
2. Clean all debris from the engine air-intake screen and around the engine.
3. Wipe up any excessive grease or oil around the engine.

Cleaning under the Machine

Service Interval: Before each use or daily

1. Stop the engine, wait for all moving parts to stop, and remove the spark-plug wire.
2. To ensure the best performance, keep the underside of the machine clean.

⚠ CAUTION

The machine may dislodge material from under the housing.

- **Wear eye protection.**
 - **Stay in the operating position (behind the handle).**
 - **Do not allow bystanders in the area.**
3. Turn the fuel shutoff valve to the off position, and drain the fuel from the fuel tank; refer to Emptying the Fuel Tank (page 20).
 4. Tilt the machine rearward until the upper handle rests on the ground, and place a jack stand under the machine.
Note: If necessary, use 2 people to tilt the machine rearward.
 5. Remove the debris with a hardwood scraper or other suitable device. Avoid burrs and sharp edges.
 6. Return the machine to the upright position.
 7. Fill the fuel tank.
 8. Connect the wire to the spark plug.

Cleaning under the Belt Cover

Service Interval: Every 50 hours

1. Stop the engine and wait for all moving parts to stop.
2. Disconnect the wire from the spark plug.
3. Remove and retain the 4 bolts, lock washers, and 2 spacers securing the belt cover to the left side of the machine.
4. Remove the cover, and brush out all the debris around the belt area.
5. Install the belt cover, and tighten all the hardware.
6. Connect the wire to the spark plug.

Cleaning the Seed Gate

1. Stop the engine and wait for all moving parts to stop.
2. Disconnect the wire from the spark plug.
3. Drain the fuel from the fuel tank; refer to Emptying the Fuel Tank (page 20).
4. Tilt the machine rearward until the upper handle rests on the ground, and place a jack stand under the machine.

Note: If necessary, use 2 people to tilt the machine rearward.

5. Clean the debris between the frame and the seed gate.
6. Lubricate the sliding surface between the frame and seed gate with a dry lubricant.
7. Return the machine to the upright position.
8. Fill the fuel tank.
9. Connect the wire to the spark plug.

Storage

1. Raise the cutting blades, stop the machine, stop the engine, and disconnect the spark-plug wire.
2. Remove dirt and grime from the entire machine.

Important: You can wash the machine with mild detergent and water. Do not pressure wash the machine. Avoid excessive use of water, especially near the engine.

3. Service the air cleaner; refer to Servicing the Air Cleaner (page 18).
4. Change the engine oil; refer to Servicing the Engine Oil (page 18).
5. Grease the slicer-shaft bearings; refer to Lubricating the Slicer-shaft Bearings (page 17).
6. For storage over 30 days, prepare the machine as follows:
 - A. Add a petroleum-based stabilizer/conditioner to fuel in the tank. Follow mixing instructions from stabilizer manufacturer. **Do not use an alcohol-based stabilizer (ethanol or methanol).**

Note: A fuel stabilizer/conditioner is most effective when mixed with fresh gasoline and used at all times.
 - B. Run the engine until it stops from running out of fuel.
 - C. Choke the engine.
 - D. Start and run the engine until it will not start again.
 - E. Dispose of fuel properly. Recycle the fuel according to local codes.

Important: Do not store stabilizer/conditioned gasoline over 90 days.

7. Check and tighten all bolts, nuts, and screws. Repair or replace any part that is damaged.
8. Paint all scratched or bare metal surfaces with paint from an Authorized Service Dealer.
9. Store the machine in a clean, dry garage or storage area.
10. Cover the machine to protect it and keep it clean.

4. Perform any needed maintenance procedures; refer to Maintenance (page 16).
5. Check the engine oil level; refer to Checking the Engine Oil Level (page 11).
6. Fill the fuel tank with fresh gasoline; refer to Filling the Fuel Tank (page 12).
7. Connect the wire to the spark plug.

Removing the Machine from Storage

1. Check and tighten all fasteners.
2. Inspect the spark plug and replace it if it is dirty, worn, or cracked; refer to the engine *Operator's Manual*.
3. Install the spark plug until it is hand-tight, then an additional 1/2 turn if it is new; otherwise, tighten it an additional 1/8 to 1/4 turn.

Troubleshooting

Problem	Possible Cause	Corrective Action
The engine will not start, starts hard, or fails to keep running.	<ol style="list-style-type: none"> 1. The fuel tank is empty. 2. The fuel shutoff valve is closed. 3. There is dirt in fuel filter. 4. Dirt, water, or stale fuel is in the fuel system. 5. The air cleaner is dirty. 6. The spark plug is old or improperly gapped. 7. The spark-plug wire is not connected. 	<ol style="list-style-type: none"> 1. Fill the fuel tank. 2. Open the fuel shutoff valve. 3. Replace the fuel filter. 4. Contact an Authorized Service Dealer. 5. Clean or replace the air-cleaner elements. 6. Adjust or replace the spark plug. 7. Check the spark-plug wire connection.
The engine loses power.	<ol style="list-style-type: none"> 1. The engine load is excessive. 2. The air cleaner is dirty. 3. The oil level in the crankcase is low. 4. The cooling fins and air passages for the engine are plugged. 5. Dirt in fuel filter. 6. Dirt, water, or stale fuel is in the fuel system. 	<ol style="list-style-type: none"> 1. Reduce the ground speed or slicing depth. 2. Clean or replace the air-cleaner elements. 3. Add oil to the crankcase. 4. Remove the obstructions from the cooling fins and air passages. 5. Replace the fuel filter. 6. Contact an Authorized Service Dealer.
The engine overheats.	<ol style="list-style-type: none"> 1. The engine load is excessive. 2. The oil level in the crankcase is low. 3. The cooling fins and air passages for the engine are plugged. 	<ol style="list-style-type: none"> 1. Reduce the ground speed or slicing depth. 2. Add oil to the crankcase. 3. Remove the obstructions from the cooling fins and air passages.
The machine pulls to the left or the right.	<ol style="list-style-type: none"> 1. The tire pressure in the drive tires is not correct. 	<ol style="list-style-type: none"> 1. Adjust the tire pressure in the drive tires.
The machine does not drive.	<ol style="list-style-type: none"> 1. The drive or pump belt is worn, loose, or broken. 2. The drive or pump belt is off a pulley. 3. The transmission oil level is low. 4. The self-propel cable needs adjustment or is broken. 	<ol style="list-style-type: none"> 1. Change the belt. 2. Change the belt. 3. Add hydraulic oil to the transmission. 4. Adjust or replace the cable.
There is abnormal vibration.	<ol style="list-style-type: none"> 1. The blade(s) is/are bent. 2. The engine mounting bolts are loose. 3. The engine pulley or idler pulley is loose. 4. The engine pulley is damaged. 5. The belt is damaged. 	<ol style="list-style-type: none"> 1. Install new blade(s). 2. Tighten the engine mounting bolts. 3. Tighten the appropriate pulley. 4. Contact an Authorized Service Dealer. 5. Install a new belt.

Notes:

Notes:

Notes:



The Toro Warranty

SWS
Turf Renovation
and
Tree Care

A limited warranty (see warranty periods below)

Conditions and Products Covered

The Toro Company and its affiliate, Toro Warranty Company, pursuant to an agreement between them, jointly warrant your Toro Products listed below to be free from defects in materials or workmanship.

This warranty covers the cost of parts and labor, but you must pay transportation costs.

The following time periods apply from the date of purchase:

Products	Warranty Period
Turf Renovation	
Walk-Behind Aerator	1 year
• Engine	2 years
Stand-On Aerator	1 year
• Battery	90 days Parts and Labor
	1 year Parts Only
• Engine	2 years
Dethatcher	1 year
• Engine	2 years
Turf Seeder	1 year
• Engine	2 years
Tree Care	
Log Splitter	1 year
• Battery	90 days Parts and Labor
	1 year Parts Only
• Engine	2 years
Stump Grinder	1 year
• Engine	2 years
Brush Chipper	1 year
• Battery	90 days Parts and Labor
	1 year Parts Only
• Engine	3 years

Where a warrantable condition exists, we will repair the Product at no cost to you including diagnosis, labor, and parts.

Instructions for Obtaining Warranty Service

If you think that your Toro Product contains a defect in materials or workmanship, follow this procedure**:

1. Contact any Authorized Servicing Outlet to arrange service at their dealership. To locate one convenient to you, access our website at www.Toro.com. Select "Where to Buy" and select "Contractor" under product type. You may also call our toll free number below.
2. Bring the product and your proof of purchase (sales receipt) to them.
3. If for any reason you are dissatisfied with the Service Outlet's analysis or with the assistance provided, contact us at:

SWS Customer Care Department
Toro Warranty Company
8111 Lyndale Avenue South
Bloomington, MN 55420-1196
Toll Free: 888-384-9940

**Toro Authorized Rental Customers who have purchased products directly from Toro and have signed the Toro Rental Customer Agreement have the ability to perform their own warranty work. Please visit Toro's Rental Portal for electronic warranty claim filing procedures or call the toll free number above.

Owner Responsibilities

You must maintain your Toro Product by following the maintenance procedures described in the *Operator's Manual*. Such routine maintenance, whether performed by a dealer or by you, is at your expense. Parts scheduled for replacement as required maintenance ("Maintenance Parts"), are warranted for the period of time up to the scheduled replacement time for that part. Failure to perform required maintenance and adjustments can be grounds for disallowing a warranty claim.

Items and Conditions Not Covered

Not all product failures or malfunctions that occur during the warranty period are defects in materials or workmanship. This express warranty does not cover the following:

- Product failures which result from the use of non-Toro replacement parts, or from installation and use of add-on, modified, or unapproved accessories
- Product failures which result from failure to perform required maintenance and/or adjustments
- Product failures which result from operating the product in an abusive, negligent or reckless manner
- Parts subject to consumption through use unless found to be defective. Examples of parts which are consumed, or used up, during normal product operation include, but are not limited to, belts, cutters, blades, teeth, spark plugs, tires, filters, etc.
- Failures caused by outside influence. Items considered to be outside influence include, but are not limited to, weather, storage practices, contamination, use of unapproved coolants, lubricants, additives, or chemicals, etc.
- Normal "wear and tear" items. Normal "wear and tear" includes, but is not limited to, worn painted surfaces, scratched decals, etc.
- Any component covered by a separate manufacturer's warranty
- Pickup and delivery charges

General Conditions

Repair by an Authorized Servicing Outlet or Self-Service as an Authorized Rental Customer is your sole remedy under the warranty.

Neither The Toro Company nor Toro Warranty Company is liable for indirect, incidental or consequential damages in connection with the use of the Toro Products covered by this warranty, including any cost or expense of providing substitute equipment or service during reasonable periods of malfunction or non-use pending completion of repairs under this warranty. All implied warranties of merchantability and fitness for use are limited to the duration of this express warranty. Some states do not allow exclusions of incidental or consequential damages, or limitations on how long an implied warranty lasts, so the above exclusions and limitations may not apply to you.

This warranty gives you specific legal rights, and you may also have other rights which vary from state to state.

Except for the engine warranty coverage and the Emissions warranty referenced below, if applicable, there is no other express warranty. The Emissions Control System on your Product may be covered by a separate warranty meeting requirements established by the U.S. Environmental Protection Agency (EPA) or the California Air Resources Board (CARB). Refer to the California Emission Control Warranty Statement supplied with your Product or contained in the engine manufacturer's documentation for details.

Countries Other than the United States or Canada

Customers who have purchased Toro products outside the United States or Canada should contact their Toro Distributor (Dealer) to obtain guarantee policies for your country, province, or state. If for any reason you are dissatisfied with your Distributor's service or have difficulty obtaining guarantee information, contact the Toro importer. If all other remedies fail, you may contact us at Toro Warranty Company.

Australian Consumer Law: Australian customers will find details relating to the Australian Consumer Law either inside the box or at your local Toro Dealer.